

High-performance sensorless vector control of induction motor drives using a Luenberger Observer

¹DJ.Cherifi, ²Y.Miloud, ¹A.Tahri

¹Department of Electrical Engineering, University of Sciences and Technology of Oran (USTO), Algeria

²Department of Electrical Engineering, University Dr. Moulay Tahar Saida, Algeria

ABSTRACT

Continuing research has concentrated on the elimination of the problem of sensitivity to parameter variation of induction motor drive. This paper presents a simple method for simultaneous estimation of rotor speed and stator resistance in sensorless indirect vector controlled induction motor drive. This method is based on luenberger observer and the stability of this observer is proved by the lyapunov's theorem, by using measured and estimated stator currents and estimated rotor flux. Finally the feasibility of the schem is verified by simulation. However, at low speed of rotation we get successful resistance identification.

Key words: Induction Motor Drive, Luenberger Observer (LO), Sensorless Indirect Vector Control, Stator Resistance Estimator, Low Speed.

Introduction

Induction motors have been widely applied in industry because of the advantages of simple construction, ruggedness, reliability, low cost, and minimum maintenance, (K. Kouzi, L. Mokrani and M-S, Nait. 2004).

Control of induction motor is complex because its mathematical model is nonlinear, multivariable, and presents strong coupling between the input, output, and internal variables, such as torque, speed, or flux.

The use of vector controlled induction motor drives allows obtaining several advantages compared to the DC motor in terms of robustness, size, lack of brushes, and reducing cost and maintenance (Y. Agrebi Zorgani, Y. Koubaa, M. Boussak. 2010), it achieves effective decoupling between torque and flux, But, the knowledge of the rotor speed is necessary, this necessity requires additional speed sensor which adds to the cost and the complexity of the drive system.

Over the past few years, ongoing research has concentrated on the elimination of the speed sensor at the machine shaft without deteriorating the dynamic performance of the drive control system, (Meziane S, Toufouti R, Benalla H.2007). The advantages of speed sensorless induction motor drives are reduced hardware complexity and lower cost, reduces size of the drive machine, elimination of the sensor cable, better noise immunity, increased reliability and less maintenance requirements. In order to achieve good performance of sensorless vector control, different speed estimation schemes have been proposed, and a variety of speed estimators exist nowadays (Yali Zhou, Yongdon Li and Zedong Zheng. 2009). Such as direct calculation method, model reference adaptive system (MRAS), Extended Kalman Filters (EKF), Extended Luenberger observer (ELO), ect.

Out of various approaches, Luenberger observer based speed sensorless estimation has been recently used, due to its good performance and ease of implementation. The Luenberger observer (LO) belongs to the group of closed loop observers. It is a deterministic type of observer because it is based on a deterministic model of the system, (Juraj Gacho, Milan Zalman.2010).

Therefore, parameter errors can degrade the speed control performance. However, the stator resistance variation has a great influence on the speed estimation at the low speed region (Han Li, Wen Xuhui, Chen Guilan. 2006). To solve the above problems, online adaptation of the stator resistance can improve the performance of sensorless IFOC drive at low speed. So, a simultaneous estimation of rotor speed and stator resistance is presented based on a luenberger observer. (S.M. Gadoue, D. Giaouris and J.W. Finch). The PI controllers for simultaneous estimators, which are also considered an important parameter for specifying the estimation process, needs to be designed to give quick transient response and good tracking performance. (Mohamed S. Zaky. 2010)

In this respect, the singular perturbation theory is used to get a sequential and simple design of the observer, and the observer stability is ensured through the Lyapunov theory. (M. Jouili, K.Jarray, Y.Koubaa and M. Boussak. 2011)

In this paper a simultaneous estimation of rotor speed and stator resistance is presented based on a luenberger observer its performances are tested by simulation, so it is organized as follows. Section 2 shows the dynamic model of induction motor; principle of field-oriented controller is given in Section 3. The proposed solution is presented in Section 4.

In Section 5, results of simulation tests are reported. Finally, Section 6 draws conclusions.

Dynamic Model of Induction Motor:

By referring to a rotating reference frame, denoted by the superscript (d,q) , the dynamic model of a three-phase induction motor can be expressed as follows maintenance (Y. Agrebi Zorgani, Y. Koubaa, M. Boussak. 2010):

$$\begin{cases} \frac{d}{dt} i_{ds} = -A_1 i_{sd} + \omega_s i_{sq} + \frac{L_m}{\sigma L_s L_r T_r} \psi_{rd} + A_2 \omega_r \psi_{rq} + A_3 V_{sd} \\ \frac{d}{dt} i_{qs} = -\omega_s i_{sd} - A_1 i_{sq} - A_2 \omega_r \psi_{rd} + \frac{L_m}{\sigma L_r L_s T_r} \psi_{rq} + A_3 V_{sq} \\ \frac{d}{dt} \psi_{dr} = \frac{L_m}{T_r} i_{sd} - \frac{1}{T_r} \psi_{rd} + (\omega_s - \omega_r) \psi_{rq} \\ \frac{d}{dt} \psi_{qr} = \frac{L_m}{T_r} i_{sq} - (\omega_s - \omega_r) \psi_{rd} - \frac{1}{T_r} \psi_{rq} \\ \frac{d\omega_r}{dt} = \frac{p}{J} (T_{em} - T_l) - \frac{f}{J} \omega \end{cases} \quad (1)$$

Where

$$A_1 = \left(\frac{R_s}{\sigma L_s} + \frac{1 - \sigma}{\sigma T_r} \right); \quad A_2 = \frac{L_m}{\sigma L_s L_r}$$

$$A_3 = \frac{1}{\sigma L_s}; \quad \sigma = 1 - \frac{L_m^2}{L_s L_r}; \quad \omega_g = \omega_s - \omega_r; \quad T_{em} = \frac{3}{2} P \frac{L_m}{L_r} (\psi_{rd} i_{sq} - \psi_{rq} i_{sd})$$

ω_s and ω_r are the electrical synchronous stator and rotor speed; σ is the linkage coefficient, and T_r is the rotor time constants.

Principle Of Field-Oriented Controller:

There are two categories of vector control strategy. We are interested in this study to the so-called IFOC. As shows in Eq (1) that the expression of the electromagnetic torque in the dynamic regime presents a coupling between stator current and rotor flux, (M. Messaoudi, L. Sbita, M. Ben Hamed and H. Kraiem. 2008).

The main objective of the vector control of induction motors is, as in DC machines, to independently control the torque and the flux; this is done by using a $d-q$ rotating reference frame synchronously with the rotor flux space vector. The d-axis is then aligned with the rotor flux space vector (Blaschke, 1972). Under this condition we get:

$$\psi_{rd} = \psi_r \text{ and } \psi_{rq} = 0$$

The torque equation becomes analogous to the DC machine and can be described as follows:

$$T_e = \frac{3}{2} p \frac{L_m}{L_r} (\psi_r i_{sq}) \quad (2)$$

It is right to adjust the flux while acting on the stator current component i_{sd} and to adjust the torque while acting on the i_{sq} component.

Using the Eq (1) we get:

$$i_{sd} = p \frac{(1 + T_r s)}{L_m} \psi_r \quad (3)$$

$$i_{sq} = \frac{T_r}{L_m} \omega_{gl}^* \psi_r^* \quad (4)$$

We replace i_{sq} by its expression to obtain T_e as function of the reference slip speed ω_{gl}^*

$$T_e = \frac{3}{2} p \frac{\psi_r^{*2}}{R_r} \omega_{gl}^* \quad (5)$$

The stator voltage commands are:

$$\left\{ \begin{array}{l} v_{sd} = R_s i_{sd} - \sigma L_s \omega_s i_{sq} + \sigma L_s \frac{di_{sd}}{dt} + \frac{L_m}{L_r} \frac{d\psi_r}{dt} \\ \quad = v_{sd1} - \omega_s \cdot \sigma \cdot L_s \cdot i_{sq} \\ v_{sq} = R_s i_{sq} + \sigma L_s \omega_s i_{sd} + \sigma L_s \frac{di_{sq}}{dt} + \frac{L_m}{L_r} \omega_s \psi_r \\ \quad = v_{sq1} - \omega_s \cdot \sigma \cdot L_s \cdot i_{sd} - \frac{L_m}{L_r} \cdot \omega \phi_r \end{array} \right. \quad (6)$$

The voltages v_{sd} and v_{sq} should act on the current i_{sd} and i_{sq} separately and consequently the flux and the torque. The two-phase stators current are controlled by two PI controllers taking as input the reference values i_{sd}^* , i_{sq}^* and the measured values. Thus, the common thought is to realize the decoupling by adding the compensation terms (\tilde{e}_{sd} and \tilde{e}_{sq}), (V. Vasic and S. Vukosavic.2001).

The block decoupling is described by the following equations:

$$\begin{aligned} \tilde{e}_{sd} &= \omega_s \cdot \sigma \cdot L_s \cdot i_{sq} \\ \tilde{e}_{sq} &= -\omega_s \cdot \sigma \cdot L_s \cdot i_{sd} - \frac{L_m}{L_r} \cdot \omega \phi_r \end{aligned} \quad (7)$$

It is necessary to determine the amplitude and the position of rotor flux. In the case of an indirect field oriented control, the module is obtained by a block of field weakening given by the following non linear relation:

$$\phi_r^* = \begin{cases} \phi_{rn} & \text{if } |\omega_r| \leq \omega_{rn} \\ \phi_{rn} \frac{\omega_{rn}}{|\omega_r|} & \text{if } |\omega_r| > \omega_{rn} \end{cases} \quad (8)$$

The slip frequency can be calculated from the values of the stator current quadrate and the rotor flux oriented reference frame as follow:

$$\begin{aligned} \omega_g &= \omega_s - \omega_r \\ &= \frac{L_m}{T_r} \cdot \frac{i_{sq}}{\phi_{rd}} = \frac{1}{T_r} \frac{i_{sq}}{i_{sd}} \end{aligned} \quad (9)$$

The rotor flux position is given by:

$$\theta_s = \int \omega_s \cdot dt = \int \left(p \cdot \Omega + \frac{L_m \cdot i_{sq}}{T_r \cdot \psi_r^*} \right) \cdot dt \quad (10)$$

Rotor Speed Regulation:

The use of a classical PI controller makes appear in the closed loop transfer function a zero, which can influence the transient of the speed. Therefore, it is more convenient to use the so-called IP controller which has some advantages as a tiny overshoot in its step tracking response, good regulation characteristics compared to the proportional plus integral (PI) controller and a zero steady-state error

$$\frac{\omega_r(s)}{\omega_r^*(s)} = \frac{k_i \cdot k_p \cdot k_t \cdot p}{J \cdot s^2 + (B + k_p \cdot k_t \cdot p) \cdot s + k_i \cdot k_p \cdot k_t \cdot p} \quad (11)$$

Where :

$$k_t = \frac{T_e}{\omega_{gl}} = p \cdot \frac{\psi_r^2}{R_r}$$

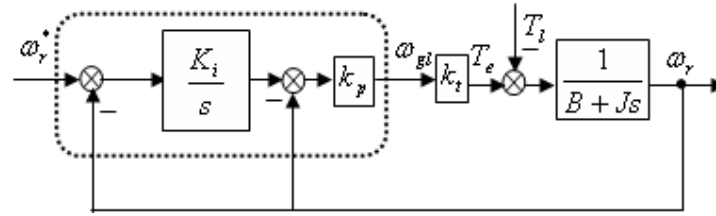

Fig. 1: Bloc diagram of IP speed controller

The gains of IP controller, K_p and K_i , are determined using a design method to obtain a trajectory of speed with the desired parameters (ξ and ω_n). The gains parameters values of the IP speed controller are easily obtained as:

$$\begin{cases} K_{p\omega} = \frac{(2 \cdot \xi \cdot \omega_n \cdot J - B) R_r}{P \cdot \psi_r^2} \\ K_{i\omega} = \frac{J \cdot \omega_n^2}{K_{p\omega} \cdot P^2 \cdot \psi_r^2} \end{cases} \quad (12)$$

According to the above analysis, the indirect field oriented control (IFOC) (Yaolong, T., Chang, J., Hualin, T.2003) of induction motor with current- regulated with PWM inverter control system can reasonably be presented by the block diagram shown in the Fig. 4.

The two PI current controllers (fig. 4) act to produce the decoupled voltages v_{sd1} and v_{sq1}

The reference voltages v_{sd}^* and v_{sq}^* determined by (6) ensure decoupled two-axes control of the induction motor drive.

Luenberger Observer:

The Luenberger observer (LO) belongs to the group of closed loop observers. It is a deterministic type of observer because it is based on a deterministic model of the system, (Juraj Gacho, Milan Zalman.2010). This observer can reconstruct the state of a system observable from the measurement of inputs and outputs. It is used when all or part of the state vector can not be measured. It allows the estimation of unknown parameters or variables of a system.

The equation of the Luenberger observer can be expressed as:

$$\begin{cases} \tilde{X} = A\tilde{X} + BU + K(Y - \tilde{Y}) \\ \tilde{Y} = C\tilde{X} \end{cases} \quad (10)$$

In this work, a sensorless Indirect Rotor-Flux-oriented Control (IFOC) of induction motor drives is studied. The strategy to estimate the rotor speed, stator resistance and the flux components is based on Luenberger state-observer (LO) including an adaptive mechanism based on the lyaponov theory, as displayed in Fig.2.

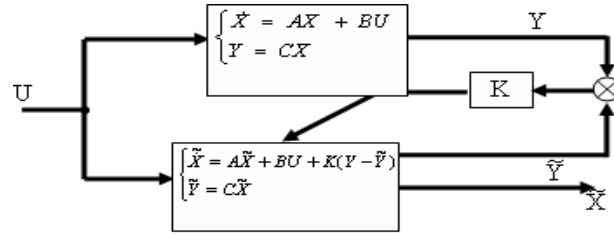

Fig. 2: structure of Luenberger Observer

Model of induction motor in the coordinate (α, β) :

The model of the induction motor can be described by following state equations in the stationary reference (α, β) :

$$\begin{cases} \dot{\hat{X}} = A.X + B.U \\ Y = C.X \end{cases} \quad (11)$$

With:

$$X = [i_{s\alpha} \quad i_{s\beta} \quad \psi_{r\alpha} \quad \psi_{r\beta}]^T; U = [v_{s\alpha} \quad v_{s\beta}]^T; Y = [i_{s\alpha} \quad i_{s\beta}]^T$$

The state equations can be written as follows:

$$\begin{cases} \hat{i}_{s\alpha} = a_1 \cdot \dot{i}_{s\alpha} + a_2 \cdot \psi_{r\alpha} - a_3 \cdot \omega_r \cdot \psi_{r\alpha} + a_6 \cdot v_{s\alpha} \\ \hat{i}_{s\beta} = a_1 \cdot \dot{i}_{s\beta} + a_2 \cdot \psi_{r\beta} + a_3 \cdot \omega_r \cdot \psi_{r\alpha} + a_6 \cdot v_{s\beta} \\ \hat{\psi}_{r\alpha} = a_4 \cdot \dot{i}_{s\alpha} + a_5 \cdot \psi_{r\alpha} - \omega_r \cdot \psi_{r\beta} \\ \hat{\psi}_{r\beta} = a_4 \cdot \dot{i}_{s\beta} + a_5 \cdot \psi_{r\beta} + \omega_r \cdot \psi_{r\alpha} \end{cases} \quad (12)$$

Where :

$$a_1 = -\frac{1}{\sigma T_s} - \frac{(1-\sigma)}{\sigma T_r}; a_2 = \frac{L_m}{\sigma L_s L_r} \cdot \frac{1}{T_r}; a_3 = -\frac{L_m}{\sigma L_s L_r}; a_4 = \frac{L_m}{T_r}; a_5 = -\frac{1}{T_r}; a_6 = \frac{1}{\sigma L_s}$$

Determination of the gain matrix:

The determination of the matrix K using the conventional procedure of pole placement. We proceed by imposing the poles of the observer and therefore it's dynamic.

Determining the coefficients of K by comparing the characteristic equation of the observer with the one we wish to impose. In developing the different matrices A, C and K we obtain the following equation:

$$p^2 + \left(\frac{1}{\sigma T_s} + \frac{1}{\sigma T_r} - j\hat{\omega}_r + K' \right) p + \left(\frac{1}{T_r} - j\hat{\omega}_r \right) \left\{ \left(\frac{1}{\sigma T_s} + \frac{1}{\sigma T_r} \right) + K' \right\} + \left(\frac{L_m}{T_r} - K'' \right) \left(\frac{L_m}{\sigma L_s L_r} \right) \left(\frac{1}{T_r} - j\hat{\omega}_r \right) = 0 \quad (13)$$

Or K' and K'' are complex gains.

The dynamics of the observer is defined by the following equation:

$$p^2 + k \left(\frac{1}{\sigma T_s} + \frac{1}{\sigma T_r} - j \hat{\omega}_r \right) p + k^2 \left(\frac{1}{T_r} - j \hat{\omega}_r \right) \left\{ \left(\frac{1}{\sigma T_s} + \frac{1}{\sigma T_r} \right) \right\} + \left(\frac{L_m}{T_r} \right) \left(\frac{L_m}{\sigma L_s L_r} \right) \left(\frac{1}{T_r} - j \hat{\omega}_r \right) = 0 \quad (14)$$

Whose roots are proportional to the poles of the MAS; the proportionality constant k is at least equal to unity ($k > 1$).

The identification of expressions (13) and (14) gives:

$$K' = (k-1) \left(\frac{1}{\sigma T_s} + \frac{1}{\sigma T_r} - j \hat{\omega}_r \right) \quad (15)$$

$$K'' = (k-1) \left\{ \left[\frac{1}{\sigma T_s} + \frac{1}{\sigma T_r} \right] \frac{\sigma L_s L_m}{L_r} - \frac{L_m}{T_r} \right\} (k-1) \frac{\sigma L_s L_m}{L_r} \left[\frac{1}{\sigma T_s} + \frac{1}{\sigma T_r} \right] + j \hat{\omega}_r \frac{\sigma L_s L_m}{L_r}$$

For the coefficients of the gain matrix of the observer is placed:

$$K' = K_1 + jK_2 \quad (16)$$

$$K'' = K_3 + jK_4$$

and in accordance with the antisymmetry of the matrix A we set the gain as follows:

$$K = \begin{bmatrix} K_1 & -K_2 \\ K_2 & K_1 \\ K_3 & -K_4 \\ K_4 & K_3 \end{bmatrix} \quad (17)$$

Or:

$$\begin{cases} K_1 = (k-1) \left(\frac{1}{\sigma T_s} + \frac{(1-\sigma)}{\sigma T_r} + \frac{1}{T_r} \right) \\ K_2 = (k-1) \cdot \hat{\omega}_r \\ K_3 = \frac{(1-k^2)}{a_3} \left(\frac{1}{\sigma L_s} + \frac{(1-\sigma)}{\sigma T_r} + \frac{a_3}{T_r} \right) + \\ \quad + \frac{(k-1)}{a_3} \left(\frac{1}{\sigma T_s} + \frac{(1-\sigma)}{\sigma T_r} + \frac{1}{T_r} \right) \\ K_4 = \frac{(k-1)}{a_3} \cdot \hat{\omega}_r \end{cases} \quad (18)$$

The poles of the observer are chosen to accelerate convergence to the dynamics of the open loop system. In general, the poles are 5-6 times faster, but they must remain slow compared to measurement noise, so that we choose the constant k usually small.

State representation of the Luenberger observer:

As the state is generally not available, the goal of an observer is to place an order by state feedback and estimate this state by a variable which we denote \hat{X} :

Where :

$$\hat{X} = [\hat{I}_{s\alpha} \quad \hat{I}_{s\beta} \quad \hat{\psi}_{r\alpha} \quad \hat{\psi}_{r\beta}]^T \quad (19)$$

So the state space of the observer becomes as follows:

$$\dot{\hat{X}} = A_{\omega_r}(\hat{\omega}_r) \cdot \hat{X} + B.U + K.(I_s - \hat{I}_s) \quad (20)$$

With

$$(I_s - \hat{I}_s) = [I_{s\alpha} - \hat{I}_s \quad I_{s\beta} - \hat{I}_s]$$

Adaptive Luenberger observer for speed estimation:

Suppose now that speed is an unknown constant parameter. It's about finding an adaptation law that allows us to estimate it. The observer can be written:

$$\dot{\hat{X}} = A_{\omega_r}(\hat{\omega}_r) \cdot \hat{X} + B.U + K.(I_s - \hat{I}_s)$$

With

$$A_{\omega_r}(\hat{\omega}_r) = \begin{bmatrix} a_1 & 0 & a_2 & -a_3 \cdot \hat{\omega} \\ 0 & a_1 & -a_3 \cdot \hat{\omega} & a_2 \\ a_4 & 0 & a_5 & -\hat{\omega}_r \\ 0 & a_4 & \hat{\omega}_r & a_5 \end{bmatrix}$$

The mechanism of adaptation speed will be reduced by Lyapunov theory. The estimation error of the stator current and rotor flux, which is simply the difference between the observer and the engine model, is given by:

$$\dot{e} = (A - K.C).e + (\Delta A) \cdot \hat{X} \quad (21)$$

With

$$\Delta A = A(\omega_r) - A(\hat{\omega}_r) = \begin{bmatrix} 0 & 0 & 0 & a_3 \Delta \omega_r \\ 0 & 0 & -a_3 \Delta \omega_r & 0 \\ 0 & 0 & 0 & -\Delta \omega_r \\ 0 & 0 & \Delta \omega_r & 0 \end{bmatrix} \quad \text{Or: } \Delta \omega_r = \omega_r - \hat{\omega}_r$$

$$e = X - \hat{X} = [e_{I_{s\alpha}} \quad e_{I_{s\beta}} \quad e_{\psi_{ra}} \quad e_{\psi_{r\beta}}]^T$$

Now consider the following Lyapunov function:

$$V = e^T e + \frac{(\Delta \omega_r)^2}{\lambda} \quad (22)$$

Its derivative with respect to time is:

$$\frac{dV}{dt} = \left\{ \frac{d(e^T)}{dt} \right\} e + e^T \left\{ \frac{de}{dt} \right\} + \frac{1}{\lambda} \frac{d}{dt} (\Delta \omega_r)^2 \quad (23)$$

$$\frac{dV}{dt} = e^T \left\{ (A - K.C)^T + (A - K.C) \right\} e - 2a_3 \Delta \omega_r \cdot (e_{I_{s\alpha}} \cdot \hat{\psi}_{r\beta} - e_{I_{s\beta}} \cdot \hat{\psi}_{ra}) + \frac{2}{\lambda} \Delta \omega_r \frac{d}{dt} \hat{\omega}_r \quad (24)$$

A sufficient condition for uniform asymptotic stability is that equation (24) is negative, which amounts to cancel the last two terms in this equation (since the other terms of the second member of (24) are always negative), in which case we can deduce the adaptation law to estimate the rotor speed by equating the second and third term of Eq.

It is estimated the speed by a PI controller described by the relationship:

$$\hat{\omega} = K_p (e_{i_{s\alpha}} \cdot \hat{\psi}_{r\beta} - e_{i_{s\beta}} \cdot \hat{\psi}_{r\alpha}) + \frac{K_i}{s} \int (e_{i_{s\alpha}} \cdot \hat{\psi}_{r\beta} - e_{i_{s\beta}} \cdot \hat{\psi}_{r\alpha}) dt \quad (25)$$

With K_p and K_i are positive constants.

Adaptive Luenberger observer for speed and stator resistance estimation:

Vector control is sensitive to the motor parameter variation. Especially, stator and rotor resistance vary widely with the motor temperature.

If the rotor speed and stator resistance are considered as variable parameters, assuming no other parameter variations, so the state space of the observer becomes as follows:

$$\dot{\hat{X}} = (A_{\omega_r}(\hat{\omega}_r) + A_{R_s}(\hat{R}_s)) \cdot \hat{X} + B.U + K \cdot (I_s - \hat{I}_s) \quad (26)$$

$$\text{With } (I_s - \hat{I}_s) = [I_{s\alpha} - \hat{I}_{s\alpha} \quad I_{s\beta} - \hat{I}_{s\beta}]$$

The estimation error of the stator current and rotor flux is given by:

$$\dot{e} = (A - K.C) \cdot e + [(\Delta A) + (\Delta A')]. \hat{X} \quad (27)$$

With :

$$\Delta A' = \begin{bmatrix} -a_6 \cdot \Delta R_s & 0 & 0 & 0 \\ 0 & -a_6 \cdot \Delta R_s & 0 & 0 \\ 0 & 0 & 0 & 0 \\ 0 & 0 & 0 & 0 \end{bmatrix}$$

A Lyapunov function candidate is defined as follows:

$$V' = e^T e + \frac{(\Delta \omega_r)^2}{\lambda} + \frac{(\Delta R_s)^2}{\lambda'} = V + \frac{(\Delta R_s)^2}{\lambda'} \quad (28)$$

$$\text{And } \Delta \omega_r = \omega_r - \hat{\omega}_r; \Delta R_s = R_s - \hat{R}_s$$

The adaptive scheme for stator resistance estimation is found by:

$$\hat{R}_s = K_p ((\hat{i}_{s\alpha} - \hat{i}_{s\alpha}) \cdot \hat{i}_{s\alpha} + (\hat{i}_{s\beta} - \hat{i}_{s\beta}) \cdot \hat{i}_{s\beta}) + \frac{K_i}{s} \int ((\hat{i}_{s\alpha} - \hat{i}_{s\alpha}) \cdot \hat{i}_{s\alpha} + (\hat{i}_{s\beta} - \hat{i}_{s\beta}) \cdot \hat{i}_{s\beta}) dt \quad (29)$$

$$\hat{R}_s = K_p (e_{i_{s\alpha}} \cdot \hat{i}_{s\alpha} + e_{i_{s\beta}} \cdot \hat{i}_{s\beta}) + \frac{K_i}{s} \int (e_{i_{s\alpha}} \cdot \hat{i}_{s\alpha} + e_{i_{s\beta}} \cdot \hat{i}_{s\beta}) dt \quad (30)$$

With :

$$i_{s\alpha} - \hat{i}_{s\alpha} = e_{i_{s\alpha}}; i_{s\beta} - \hat{i}_{s\beta} = e_{i_{s\beta}}$$

K_p and K_i are positive constants. The role of adaptive mechanisms is to minimize the following errors.

Finally, the value of speed and stator resistance can be estimated by simple PI controllers.

The structure of the proposed adaptive observer for speed and stator resistance estimation is shown in Fig.

3. These adaptive schemes were derived by using the Lyapunov's stability theorem.

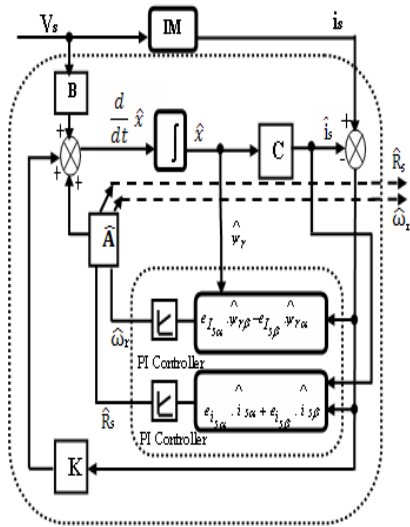

Fig. 3: Block diagram of simultaneous estimation of rotor speed and stator resistance

The block diagram of a rotor flux oriented induction motor drive, together with both rotor speed and stator resistance identifications, is shown in Fig. 4.

It mainly consists of a squirrel-cage induction motor, a traingulo sinusoidal voltage controlled pulse width modulated (PWM) inverter, a slip angular speed estimator, equipped with luenberger observer.

The induction motor is three-phase, Y-connected, four pole, 1.5 Kw, 220/380V, and 50Hz. The torque component voltage command v_{qs} is generated from the speed error between the command and the estimator rotor speed through the torque controller.

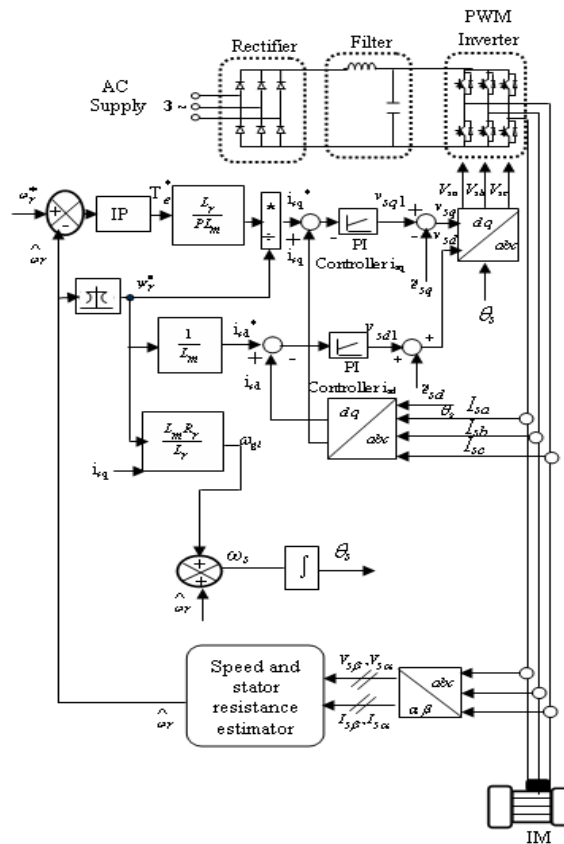

Fig. 4: Block diagram of sensorless (IFOC) with stator resistance tuning of induction motor drive system.

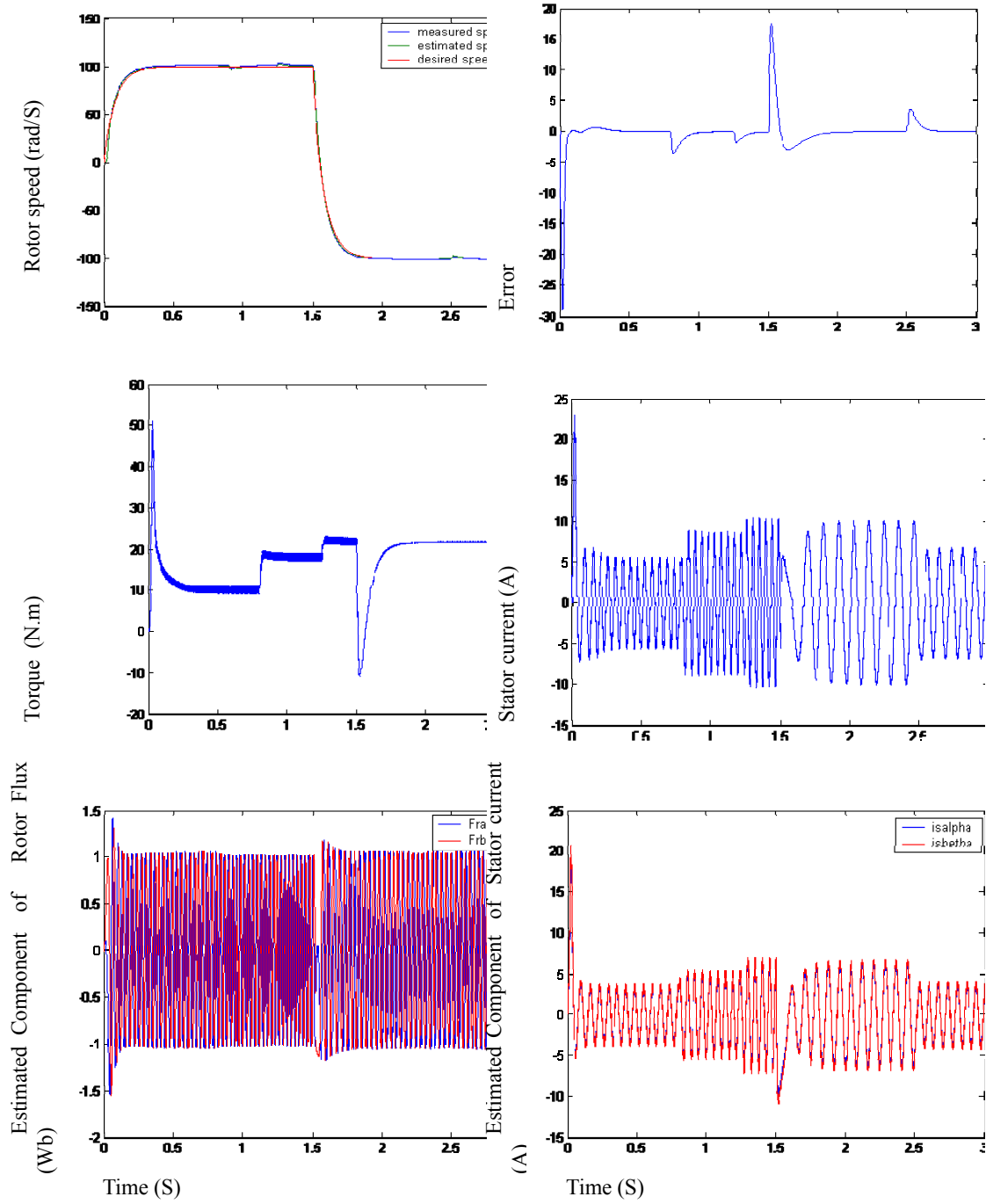

Fig. 5: Performances of speed control using an L O proposed with a speed reverse and under load change.

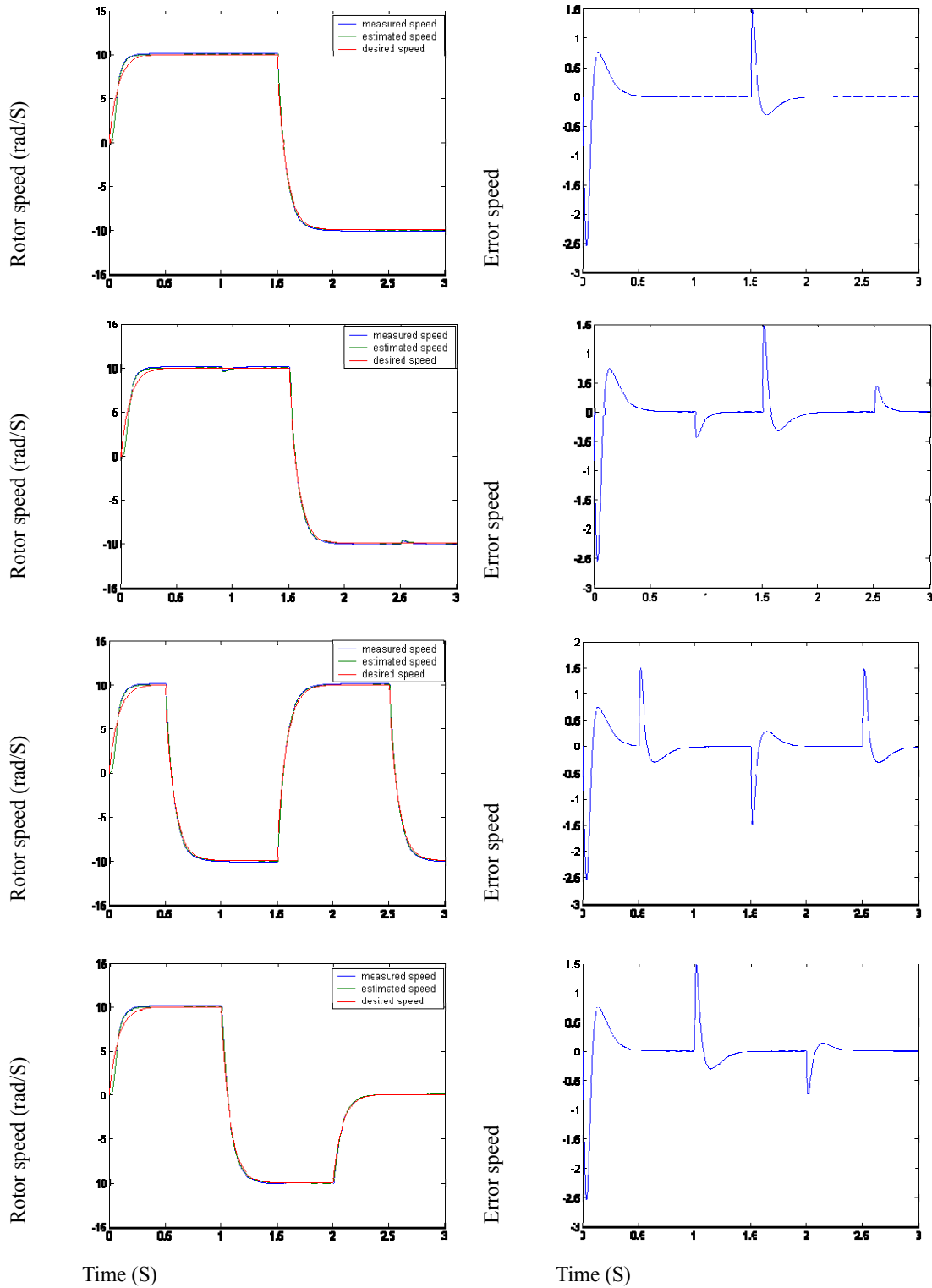

Fig. 6: Simulated speed response for step varying of the reference speed

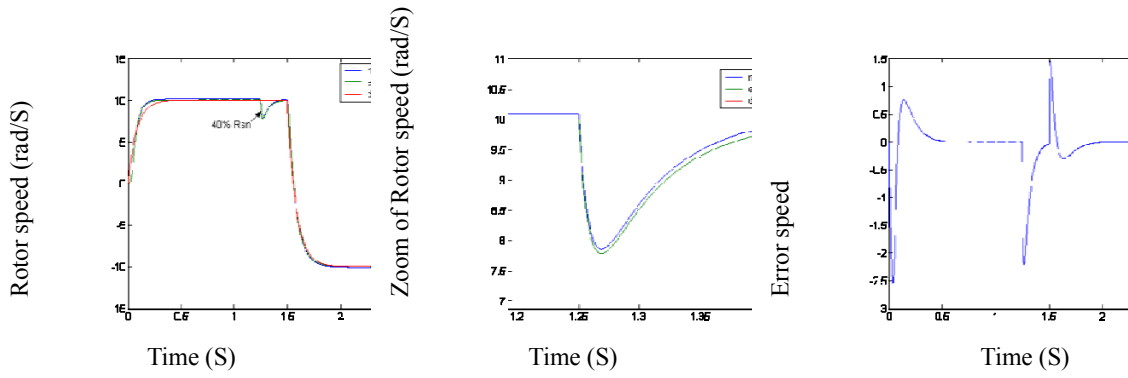

Fig. 7: Simulation results of the speed estimation with stator resistance increased sharply by 40% from R_{sn}

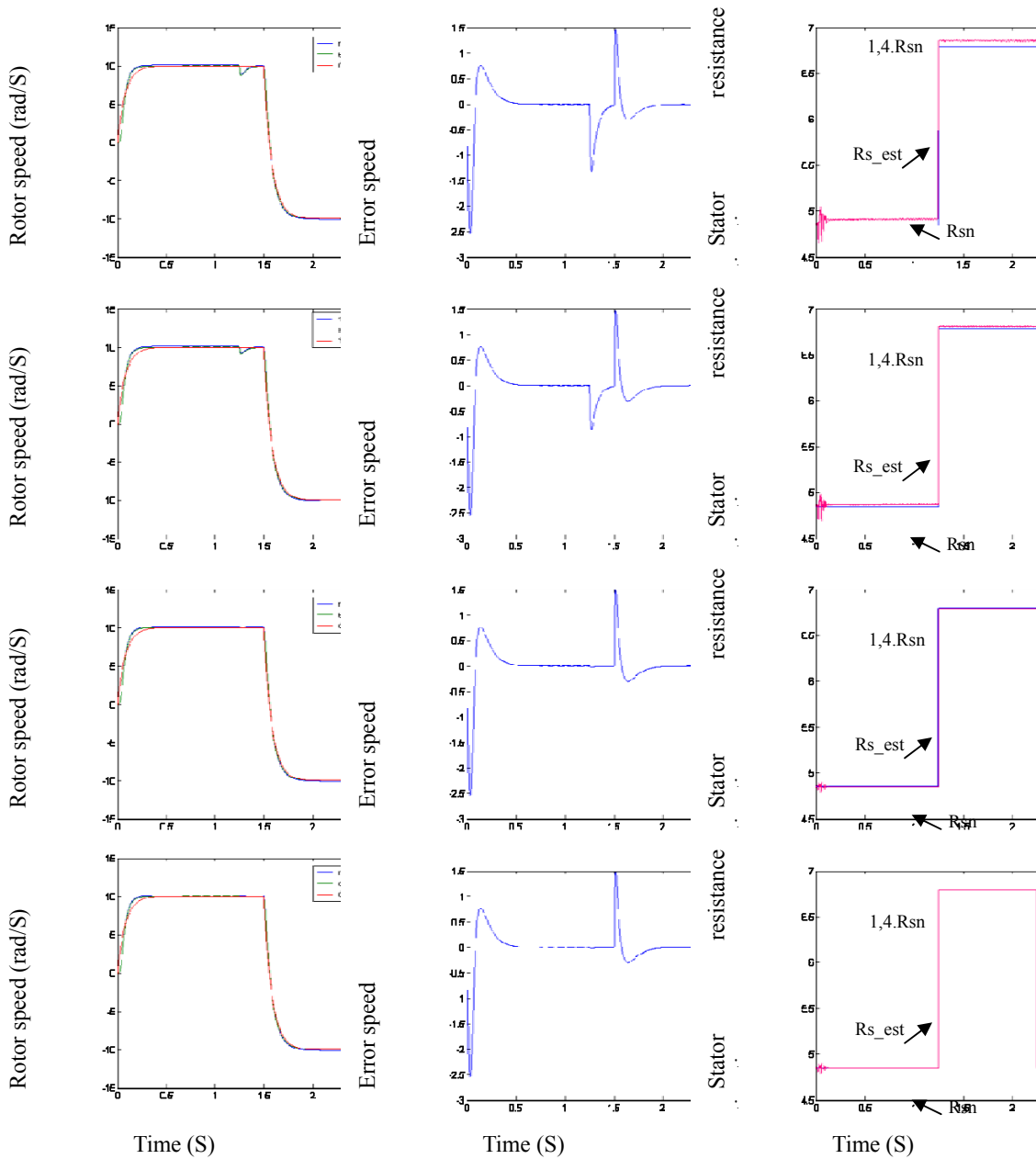

Fig. 8: Simulation results of the speed and stator resistance estimation

Results and Discussion

The above presented procedure has been simulated using Matlab-Simulink Software. Figure.4 shows the simulation block diagram of IFOC induction motor drive system with simultaneous estimation of the stator resistance and rotor speed,

The parameters of the induction motor used are given in appendix.

Figure 5 shows the response of the proposed variable speed sensorless system for a step reference since 0 rad/sec for 100 rad/sec, and a reverse speed to -100 rad/sec, under load change. Disturbances are introduced by applying and removing a load torque equal to 10N.m at 0.8, then reapplying the same load torque at 2.5 second but at 1.25 second the resistance value increased sharply by 40% from its nominal value. These results show clearly very satisfactory performances in tracking, and very low time of reaction in transient state. The actual motor speed perfectly follows the reference trajectory, and the observer's response illustrates an excellent precision of the estimated speed and fluxes.

In Fig. 6, the figure shows the simulation results of actual and estimated speed for step changing of reference from 10 rad/sec to -10 rad/sec, and the nether one shows the speed error in the corresponding process. It is shown that the estimated speed tracks the actual and the reference speed accurately.

In order to investigate the performance of the drive for parameter variations in stator resistance, a series of simulations were conducted at 10 rad/sec and with a constant load torque of 10 Nm, figure 8 shows the performances of the estimation of rotor speed and stator resistance at speed 10 rad/sec the resistance value increased sharply by 40% from its nominal value at time 1.25 second. In which the R_s denotes the stator resistance.

In Fig. 7 simulation results of the speed estimation without stator resistance compensator is given, we can see from Fig. 7, on the condition that the actual stator resistance is changed by %40; the speed estimation is inaccurate when the stator resistance compensator is inactive. There is speed estimation error.

Fig. 8. Shows the simulation results of a simultaneous estimation of rotor speed and stator resistance. As shown in this figure, the speed identification is worked perfectly well except for a little oscillation in the beginning of the process. The reason for this is that there is initial error in the estimated stator resistance, with time goes on, the adaptation mechanism quickly compensates the initial error and therefore, compensates the initial speed estimation error.

As shown in Fig. 8, the blue line denotes the actual value of stator resistance while the red one for estimated one, the latter track the former accurately, which proves the validity of the proposed scheme.

Conclusion:

This paper has presented simultaneous estimation of rotor speed and stator resistance based on a luenberger observer. A robust adaptive flux observer is designed for a speed sensorless IFOC-controlled induction motor drive.

The proposed control scheme system was designed and analyzed under various operating conditions, and its effectiveness in tracking application was verified at high and low speed. So, the influence of the stator resistance variation on the speed estimation can be weakened to the minimum. The effectiveness of the method is verified by simulation

Appendix:

Table 1: Induction Motor Parameters

50 Hz, 1.5 Kw , 1420 rpm, 380 V, 3.7A	
Rotor resistance	$R_r = 3.805\Omega$
Stator resistance	$R_s = 4.85\Omega$
Rotor inductance	$L_r = 274$ mH
Stator inductance	$L_s = 274$ mH
Moment of inertia	$J = 0.031$ kg.m ²
Friction coefficient	F=0.00114kg.m ² /s

References

Kouzi, K., L. Mokrani and M-S, Nait, 2004. "High Performances of Fuzzy Self-Tuning Scaling Factor of PI Fuzzy Logic Controller Based on Direct Vector Control for Induction Motor Drive without Flux Measurements", *IEEE International Conference on Industrial Technology*

- Agrebi Zorgani, Y., Y. Koubaa, M. Boussak, 2010. "Simultaneous Estimation of Speed and Rotor Resistance in Sensorless ISFOC Induction Motor Drive Based on MRAS Scheme", XIX International Conference on Electrical Machines - ICEM, Rome
- Meziane, S., R. Toufouti, H. Benalla, 2007. MRAS based speed control of sensorless induction motor drives. ICGST-ACSE Journal, 7(1): 43-50.
- Yali Zhou, Yongdon Li and Zedong Zheng, 2009. "Research of Speed sensorless Vector Control of an Induction Motor Based on Model Reference Adaptive System" IEEE.
- Juraj Gacho, Milan Zalman, 2010. "IM Based Speed Servodrive With Luenberger Observer", Journal of Electrical Engineering, 61(3): 149-156.
- Han, Li, Wen Xuhui, Chen Guilian, 2006. "General Adaptive Schemes for Resistance and Speed Estimation in Induction Motor Drives", IEEE COMPEL Workshop, Rensselaer Polytechnic Institute, Troy, NY, USA, 16-19.
- Gadoue, S.M., D. Giaouris and J.W. Finch, "ANew Fuzzy Logic Based Adaptation Mechanism for MRAS Sensorless Vector Control Induction Motor Drives"
- Mohamed, S., Zaky, 2010. "Stability Analysis of Simultaneous Estimation of Speed and Stator Resistance for Sensorless Induction Motor Drives", Proceedings of the 14th International Middle East Power Systems Conference (MEPCON'10), Cairo University, Egypt, ID 180.
- Mabrouk Jouili, Kamel Jarray, Yassine Koubaa and Mohamed Boussak, 2011. "A Luenberger State Observer for Simultaneous Estimation of Speed and Rotor Resistance in sensorless Indirect Stator Flux Orientation Control of Induction Motor Drive", IJCSI International Journal of Computer Science Issues, 8(6): 3.
- Messaoudi, M., L. Sbita, M. Ben Hamed and H. Kraiem, 2008. "MRAS and Luenberger Observer Based Sensorless Indirect Vector Control of Induction Motors", Assain Journal of Information Technology, 7(5): 232-239.
- Vasic, V. and S. Vukosavic, 2001. "Robust MRAS-based algorithm for stator resistance and rotor speed identification," *IEEE Power Engineering Review*,
- Yaolong, T., J. Chang, T. Hualin, 2003. 'Adaptive Backstepping Control and Friction Compensation for AC Servo with Inertia and Load Uncerainties', IEEE Trans. On Ind. Elect., 50(5): 145-155.